

DIGITAL DIRECT COMPOSITE FUNCTION GENERATOR

OPERATION MANUAL

1. GENERAL

The instrument is a DDS digital direct composite function generator. It is cored by CPU, employs many large scale integrated circuits, it has the following features:

- (1) High precise for frequency, high stability.
- (2) Purity waveform, small distortion.
- (3) Non-transition process, fast frequency change-over time: can be stable instant
- (4) Non-limitation on ranges: unnecessary to changes ranges, frequency covering factor can be 10^8
- (5) Sweeping characteristics: many kinds of sweeping modes are selectable and can pause randomly, LED will display the current frequency value; can sweep meticulously on narrow band; can set initial frequency, terminal frequency, sweeping steps and time interval.
- (6) Modulation characteristics: it has amplitude modulation function, the modulation signal can be generated by either inner signal source or outer input, the depth is adjusted and will not be effected by carrier wave frequency and output amplitude.
- (7) Convenient keyboard operation.
- (8) Stability and reliability.

2. TECHNICAL DATA AND SPECIFICATON

2-1. WAVEFORM CHARACTERISTIC:

sine-wave, TTL level square wave

waveform amplitude resolution: 10bit

sine wave harmonic distortion: -40dBc (frequency < 1M Hz), -30dBc (frequency \geq 1M Hz)

sine wave THD: < 1% (high resistance, 1KHz)

TTL level square wave rise time: \leq 20ns

Square wave overshoot: \leq 5%

2-2. FREQUENCY CHARACTERISTIC:

frequency range: 1Hz — 3MHz

resolution: less than 1MHz: 0.01Hz ; 1MHz and more than 1MHz: 0.1Hz

frequency tolerance: $\leq \pm (5 \times 10^{-5} + 30\text{Hz} + 1\text{d})$

frequency stability: $\leq \pm 50\text{ppm}$ (-40°C — $+85^\circ\text{C}$) (use the low temperature drift crystal oscillator with PLL phase-lock circuit) . Custom-made can be done if frequency stability requires to be $\pm 20\text{ppm}$ or less.

2-3. AMPLITUDE CHARACTERISTIC:

amplitude range: $10\text{mV}_{\text{p-p}}$ — $16\text{V}_{\text{p-p}}$ (high resistance), $5\text{mV}_{\text{p-p}}$ — $8\text{V}_{\text{p-p}}$ (50Ω)

display: 3 digits

amplitude error: $\leq \pm (5\% + 100\text{mV}_{\text{p-p}})$ (high resistance, 1KHz, 1— $16\text{V}_{\text{p-p}}$)

amplitude stability: $\leq \pm 5\%$ (1hr, high resistance, 1KHz, $16\text{V}_{\text{p-p}}$)

flatness: $\leq \pm 0.5\text{dB}$ ($\leq 100\text{KHz}$), $\leq \pm 0.8\text{dB}$ (100KHz — 1MHz), $\leq \pm 2\text{dB}$ (1MHz — 2MHz), $\leq \pm 3\text{dB}$ (2MHz — 3MHz), (less than 1Hz, the frequency amplitude is unstable)

output impedance: 50Ω ($\pm 10\%$)

TTL level output characteristic: low level: $< 0.3\text{V}$; high level: $> 4.2\text{V}$ (high resistance)

2-4. DRIFT CHARACTERISTIC:

drift range: 0V — $\pm 6.4\text{V}$ (high resistance), 0V — $\pm 3.2\text{V}$ (50Ω)

resolution: 50mV (high resistance)

drift error: $\leq \pm (5\% + 100\text{mV})$ (1hr, high resistance, 1KHz, $10\text{V}_{\text{p-p}}$)

2-5. MODULATION CHARACTERISTIC:

amplitude modulation: AM

modulate waveform: (interior amplitude modulation) sine wave: $400\text{Hz} \pm 10\%$, $1000\text{Hz} \pm 10\%$ 2 ranges

modulation depth: 1% — 100%

modulation source: inner modulation source, outer modulation source

outer modulation characteristic: input impedance: 600Ω

input level: the modulation depth is 50% at 0dB

input frequency response: 100Hz — 100KHz ($\pm 3\text{dB}$)

2-6.SWEEP CHARACTERISTIC:

Frequency sweep mode: linearity, logarithm

During frequency sweep, the frequency and amplitude value will be displayed synchronistically, and can stop at any sweeping point. It will go on sweeping or restart after pausing.

sweep rate: 0.02s —5s/step, 5-digit can be set

logarithm sweeping characteristic: 100 points per 10 times frequency ranges

2-7. DISPLAYING:

8-digit LED displaying with F,V, AM, SWEEP, MHz, KHz, Hz, %/s indicator and every range

2-8.POWER SOURCE: AC 220V/110V ±10%, frequency: 50Hz/60Hz±5%

2-9.AMBIENT TEMPERATURE AND HUMIDITY: 0 — 40°C ,30% — 70% RH

2-10.DIMENSION: 270mm×215mm×100mm

2-11.WEIGHT: 1.9 kg

3. PANEL DESCRIPTION

see the fig.

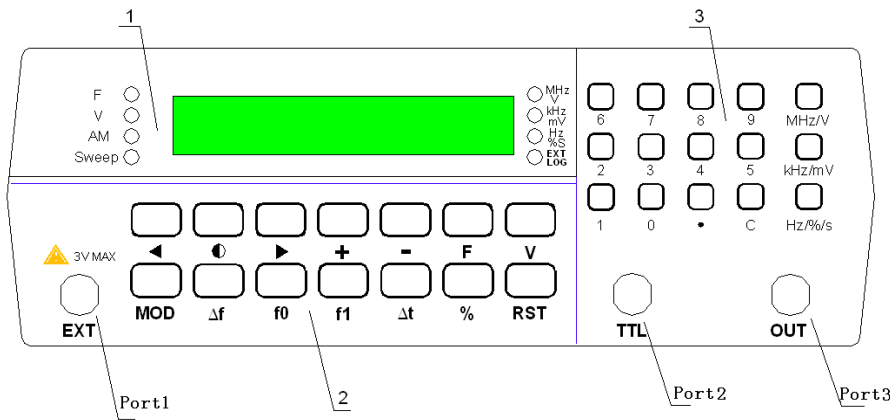

3-1.DISPLAYING AREA: the displaying area consists of 8 LED-indicators and 8 LED-displays, see the fig.

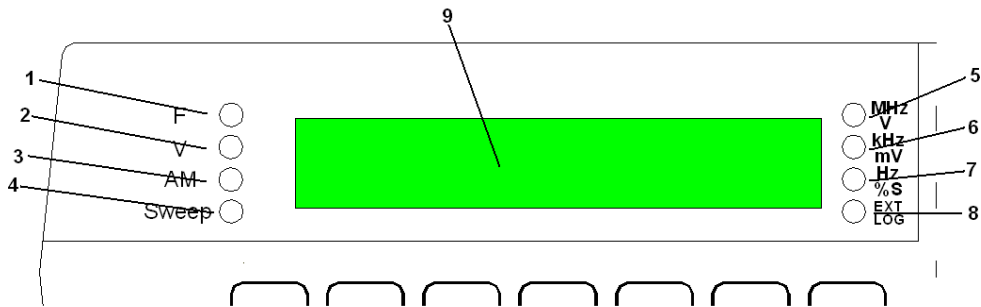

- 1. <F> frequency indicator
- 2. <V> voltage indicator
- 3. <AM> modulation indicator
- 4. <Sweep> sweep indicator
- 5. <MHz/V> MHz or V unit indicator
- 6. <KHz/mV> KHz or mV unit indicator
- 7. <EXT/LOG> indicator for outer modulation and logarithm sweep
- 8. <Hz%/S> Hz or second (S) unit or modulation depth indicator (%)
- 9.LED displaying

3-2.FUNCTION KEY AREA: it consists of 14 keys. See the fig.

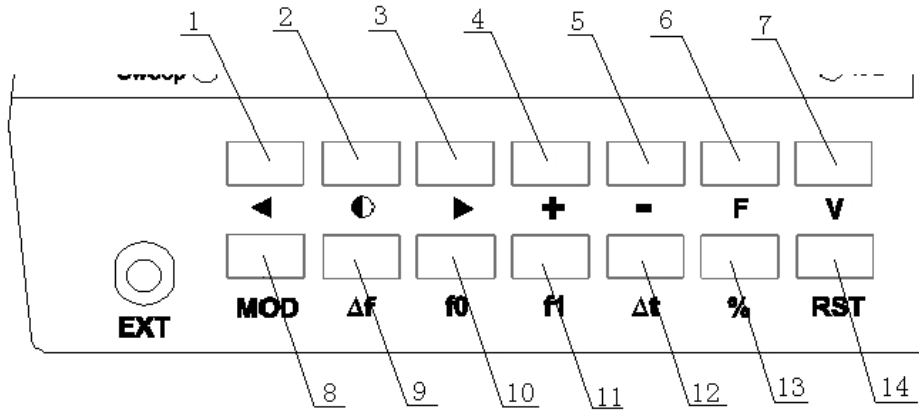

1. <←> blinking bit shifts left 2. <↔> blink activation key 3. <→> blinking bit shifts right
 4. <+> blinking number increase and positive level DC offset 5. <-> blinking number decrease and negative level DC offset 6. <F> frequency setting displaying key
 7. <V> voltage setting displaying key 8. <MOD> functional mode selector 9. <Δf> spacing frequency key
 10. <f₀> 400Hz inter-modulation signal and sweeping initial frequency setting key 11. <f₁> 1000Hz inter-modulation signal and sweeping terminal frequency setting key
 12. <Δt> frequency sweep time interval setting key 13. <%> modulation depth setting key 14. <RST> reset key

3-3. NUMBER KEY AREA: consists of 15 keys, see the fig.

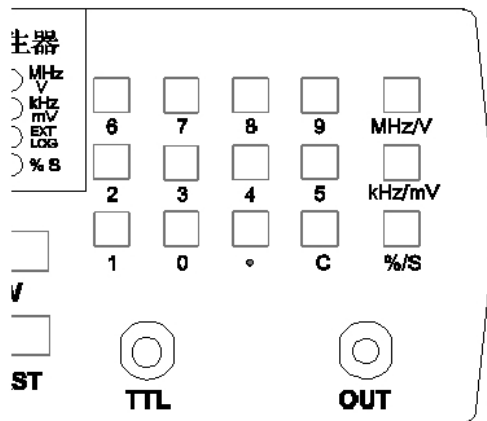

Among them, there are 10 number keys: “.” Decimal point key, “C” backspace key, “MHz/V” MHz or V unit key, “kHz/mV” kHz or mV unit key, “Hz/%/S” Hz unit key or modulation depth % or S unit key

3-4. TERMINAL DESCRIPTION:

TERMINAL 1 (EXT) outer-modulation signal input terminal; TERMINAL 2 TTL level square wave output terminal; TERMINAL 3. sine wave output terminal

3-5. REAR PANEL DESCRIPTION: SEE THE FIG.

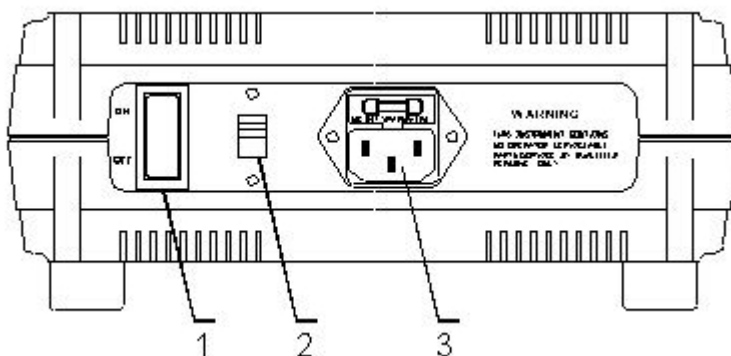

1. POWER SWITCH 2. 220V/110V SWITCHER 3. POWER SOCKET AND FUSE BOX (0.5A)

4. DIRECTIONS FOR USE:

4-1. START-UP:

Firstly, check if the voltage and frequency of the power can match the instrument, and set the AC 220V/110V switcher to a correct position, then, plug in the power cord, turn on the power, LED will display the model “2003”, after 2 seconds, the instrument goes into operating mode. We suggest that before operation, the instrument should be preheated for 30 minutes.

4-2.DATA INPUT:

There are two ways for data input: (1) digital input: input by number keys from right shift to left shift, if exceed the resolution, input can not be done. If the data is out of scope, will output the proximal data. If wrong input, press “C” to clear the final bit, then ,input correct data. When finishing input, only when unit is input, will the data be input into the instrument. During this procedure, the output signal is still output according to the previous data output. The way is suitable for the input of random value. (2) data modification: to active the digit by “☼” key in the function area, press “◀” and “▶” key can change the digit needed to be modified; press “+” or “-” key to increase or decrease data. To cancel the mode, press “☼” key again. During this procedure, the output varies continuously. The way is suitable for modifying and input proximal data.

4-2-1.FREQUENCY SETTING

Press “F” key in the function area, the indicator will light, and the current output frequency value will be displayed on LED. If want to change frequency, input frequency value directly, during input, the previous frequency will not be changed. If the input data is over 8-digit or over scope, the proximal frequency will be set. If wrong input, if do not input unit, the data can be modified. To keep the original data, press “F” key.

When the input frequency value is close to the primary one, press “☼” key to active the final bit so long as the current displaying is frequency value, and it is unnecessary to press “F” key. Press “◀” or “▶” key can select the digit needed to be modified, press “+” or “-” key can increase or decrease the value and can increase or decrease bit continuously. The frequency of the output signal is in synchronism with that of displaying and will not be interrupted.

For example, if output a signal of 3.5KHz, take the following operation:

press “F” key, then, press “3”, “.”, “5”, “KHz/mV” in turn

If output a signal of 0.56MHz, take the following operation:

press “F” key, then, press “0”, “.”, “5”, “6”, “MHz/V” in turn; It is the same to press “5”, “6”, “0”, “KHz/mV” .

4-2-2.AMPLITUDE AND DC OFFSET SETTING:

Press“V” key in the function area, and the indicator lights, the current output amplitude value will be displayed on LED, the value is the peak-peak value on high resistance load. If the load is 50Ω , the actual output peak-peak value of the voltage is just a half of this value. You can input directly by number keys and vernier control by function keys, the concrete operation is similar to frequency input.

For example, if want to output a signal with amplitude 10V_{p-p}

Press “V” key, then, press “1”, “0”, “MHz/V” key in turn.

If there is a certain DC video component in the output AC signal, i.e., need to DC offset or drift, press “V” key in function area, then, “+” or “-” key, input the polarity of DCV which needed to be offset, and the LCD will display “P— ***”, it refers to the current DC drift rate (high resistance), thence, input the DCV value needed to be offset.

For example, if the output signal drifts +2.5V

Press “V” key and then “+” key, input “2”, “.”, “5”, “MHz/V” in turn.

Every time, when turn on the power or reset, the DC drift will be the default value 0V.

4-2-3.MODE SETTING:

The “MOD” selector can select output mode, in turn, there is : COMMON→INNER- MODULATION → OUTER-MODULATION →LINEARITY FREQUENCY SWEEP → LOGARITHM FREQUENCY SWEEP →COMMON→…recycled, see the fig.

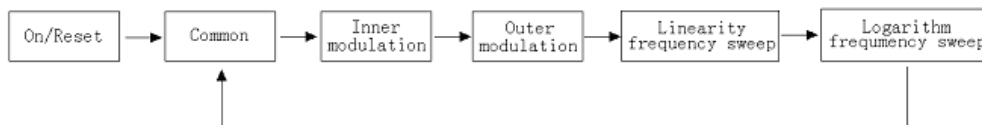

MOD key selecting sequence flow

4-2-3-1.COMMON MODE: it refers to the mode only set “F” and “V”, and it is the default mode for the instrument. .

4-2-3-2.INNER MODULATION SETTING:

Press“MOD” selector to select inner-modulation mode, “AM” indicator lights, the instrument is in inner-modulation mode. Press“F” key to set carrier wave; press“V” key to set t he amplitude of output signal; press “%” key to set modulation depth (modulation factor) . There are 2 modulation signals for inner-modulation: 400Hz and 1000Hz, press f₀ to select 400Hz modulation signal, the instrument displays “0—0.400kHz, press f₁ to select 1000Hz modulation signal, the instrument displays “0—1.000kHz.

For example, if want to get a signal with carrier frequency 630KHz, frequency of modulation signal is 1000Hz, modulation depth is 30% and output amplitude is 2V_{p-p}.

Press “MOD” key to be into inner-modulation mode;

Press “F” key to set carrier frequency, input “6”, “3”, “0”, “KHz/mV” in turn to set output frequency;

Press “f₁” key to set the modulation signal as 1000Hz;

Press “%” key and input “3”, “0”, “%/S” to set modulation depth;

Press “V” key to set output amplitude, press “2”, “MHz/V” in turn to set output amplitude, and it completes.

During operation, the sequence is random to set carrier frequency, amplitude, depth and modulation signal.

4-2-3-3. OUTER-MODULATION SETTING:

When the inner-modulation parameter can not meet the requirement, you can set the instrument to outer-modulation mode. Press “MOD” key to select outer-modulation mode, and “AM” and “EXT/LOG” indicator light, the instrument is in outer-modulation mode. Input the outer-modulation signal from “EXT” terminal; Press “F” key can set carrier wave frequency; Press “V” key can set the amplitude of the output signal; Due to the modulation depth relates to the magnitude of the outer-modulation signal, the inner-modulation depth setting will not take function. The basic setting is the same as that of inner-modulation, and it is unnecessary to set modulation depth and frequency of inner-modulation signal.

The seemingly frequency of outer-modulation signal is between 100Hz—100KHz, the input impedance for “EXT” terminal is 600 Ω, when input signal is 0dB, the modulation depth is 50%; when input signal is +6dB, the modulation depth is 100%, the max. is approx. 150%.

4-2-3-4. LINEARITY FREQUENCY SWEEP:

Press “MOD” key to select linearity sweep, and “Sweep” indicator light, the instrument is in linearity frequency sweep mode, press “f₀” key to select initial frequency, then, the screen displays “0—*****”; press “f₁” key to set terminate frequency, the screen displays “1—*****”; press “Δf” key to set spacing frequency, the screen displays “2—*****”; press “Δt” key to set sweep time interval. After finishing setting “Δt”, it begins to cycle sweep according to positive linearity. It is suitable for sweeping in a narrower frequency band.

For example, if you want to sweep between 1KHz to 1.1KHz by the frequency step value of 1Hz, set the time interval as 1s:

press “MOD” key to select linearity sweep mode;

press “f₀” key and “1”, “KHz/mV” key to set initial frequency;

press “f₁” key and “1”, “.”, “1”, “KHz/mV” key to set terminate frequency;

press “Δf” key and “1”, “Hz/%S” key to set sweep spacing frequency;

press “Δt” key and “1”, “%/S” key to set time interval; and then, sweep begins.

4-2-3-5. LOGARITHM FREQUENCY SWEEP:

Press “MOD” key to select logarithm frequency sweep, and “Sweep” and “EXT/LOG” indicator light, the instrument is in logarithm frequency sweep mode, press “f₀” key to set initiate frequency; press “f₁” key to set terminate frequency; press “Δt” key to set time interval. After finishing setting “Δt”, sweep begins. The setting way and displaying are the same as that of linearity sweep, and it is unnecessary to set “Δf”. It is suitable for sweeping in a wider frequency band.

For example, if want to make logarithm sweep between 20Hz and 20KHz, time interval is 0.1s, take the following operations:

Press “MOD” key to select logarithm sweep mode;

Press “f₀” and press “2”, “0”, “Hz/%S” key to set initial frequency;

Press “f₁” key and press “2”, “0”, “KHz/mV” key to set terminal frequency;

Press “Δt” key and press “0”, “.”, “1”, “%/S” key to set time interval, then, sweep begins.

EXPLANATION FOR FREQUENCY SWEEP:

No matter which mode the frequency sweep is in, press any keys of “f₀”, “f₁”, “Δf”, “Δt” to stop sweeping, press “%/S” key to pause, then, the screen displays the frequency of the pausing point, and will output this value. When press “%/S” key again, it will go on sweeping. If need to restart, press “Δt” key and then “%/S” key. The sweep begins with finishing input the unit of time interval “Δt”, so, time interval should be set lastly.

For digital input mode, if the digit before decimal point is “0”, the “0” can not be omitted.

For any frequency output, TTL level square wave is in synchronism with sine output, and it is unnecessary to switch ranges; After power off or reset, the setting data on each ranges become the default value (F=1KHz, V=1V, DC offset=±0.15V, AM modulation frequency=400Hz, AM modulation amplitude m=50%, sweep initial frequency f₀=1KHz, sweep terminal frequency f₁=10KHz, sweep interval frequency Δf=1KHz, sweep interval time Δt=1s).

5. NOTES:

- 5-1. There should not exist DC and high voltage and strong radiance signal on the load of the generator to prevent from damaging the instrument.
- 5-2. When the instrument appears the problem, such as un-normal displaying, breaking down, etc. just press reset key or turn off the power, the problem will be solved.
- 5-3. If there is a lower DC in load circuit or DC component is unnecessary, you can joint-connect a capacitor with proper capacitance and withstand voltage to interclude DC.
- 5-4. It is better not to connect a oversize load on TTL level output, otherwise, it will lead to wave form distortion, long rising time.
- 5-5. Do not expose the instrument to extremes of temperature and humidity, dusty place and strong radiance and electromagnetic interference environment, and avoid violent shock.

6. FUNCTIONAL BLOCK DIAGRAM :

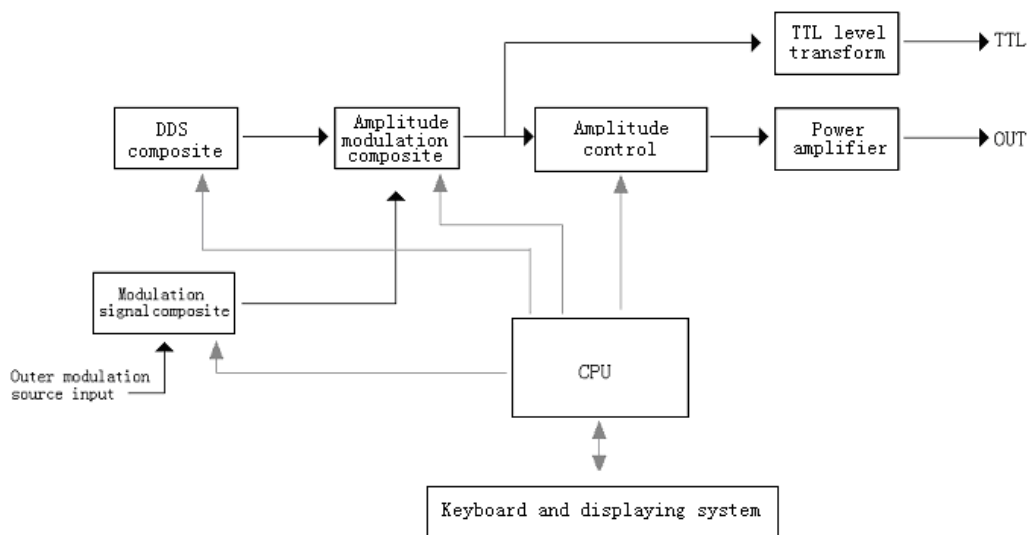

7.NOTES:

The specifications are subject to change without notice.

The content of this manual is regarded as correct,if any error or in doubt,please contact us.

We will not be responsible for accident or injury caused by improper operation.

The function described in this manual can not be the reason of special usage.